



SU-MO



SU-CL



SU-VA



SU-CU



SU-AB



SU-CA



CO-AR

CARACTERISTIQUES

- Systèmes de fixation rapide sur les profilés et sur les structures métalliques.
- Fixation rapide par coup de marteau sur le clip dans la gamme SUCU, SUVA, SUCL et par filetage dans la gamme SUMO.
- Disponible dans une large gamme de dimensions.
- Hautes valeurs de résistance mécanique aux systèmes de suspension.
- Applicable sur une large gamme d'épaisseurs de profilés pour structures.
- Application : plafonds suspendus, systèmes avec tige entièrement fileté, fixation de tuyaux avec des colliers, etc.





















MATERIEL



EXEMPLES D'APPLICATION



1. GAMME

ITEM	PHOTO	CODE	DESCRIPTION	MATERIEL	REVÊTEMENT
1		SUMOP09	Pince pour poutre	 Acier	 Zinguée ≥ 5µm
		SUMOP11			
		SUMOP13			
		SUMOM06			
		SUMOM08			
		SUMOM10			
2		SUCL02	Clip suspension	 Acier	 Phosphaté ≥ 5µm
		SUCL04			
		SUCL10			
		SUCL15			
3		SUVA0602	Clip angulaire pur tige filetée	 Acier	 Phosphaté ≥ 5µm
		SUVA0604			
		SUVA0610			
		SUVA0615			
		SUVA0802			
		SUVA0804			
		SUVA0810			
4		SUCU0602	Clip droit pour éléments de suspension	 Acier	 Phosphaté ≥ 5µm
		SUCU0605			
		SUCU0606			
		SUCU0607			
5		SUAAB0603	Clip de poutre pour pince	 Acier	 Phosphaté ≥ 5µm
		SUAAB0607			
		SUAAB0614			
6		SUCA0602	Clip de poutre pour câble	 Acier	 Phosphaté ≥ 5µm
		SUCA0604			
		SUCA0607			
		SUCA0802			
		SUCA0804			
		SUCA0807			
		SUCA1002			
		SUCA1004			
		SUCA1007			
		SUCA1202			
		SUCA1204			
		SUCA1207			
		SUCA1502			
		SUCA1504			
		SUCA1507			
		SUCA1902			
SUCA1904					
SUCA1907					
SUCA2502					
SUCA2504					
SUCA2507					
7		COAR08060	Crochet articulé	 Acier	 Zinguée ≥ 5µm
		COAR10060			

2. DONNÉES D'INSTALLATION

2.1 SU-MO

Pince pour poutre



Matériel

Revêtement



Acier

Zinguée $\geq 5\mu\text{m}$

Données d'installation

Code	A	B	C	D	E	Ø DEBOUCHANT	TYPE D'INSTALLATION	COUPLE DE SERRAGE
	[mm]	[mm]	[mm]	[mm]	[mm]	[mm]	[--]	[Nm]
SUMOP09	38	35	37	18	20	THROUGH HOLE 9	THREADED ROD + NUT OR CABLE	10
SUMOP11	44	41	42	21	20	THROUGH HOLE 11		15
SUMOP13	57	48	54	24	25	THROUGH HOLE 13		20
SUMOM06	38	35	37	18	20	THREADED M6	THREADED ROD + NUT	10
SUMOM08	38	35	37	18	20	THREADED M8		10
SUMOM10	44	41	42	21	20	THREADED M10		15
SUMOM12	57	48	54	24	25	THREADED M12		20

Plan

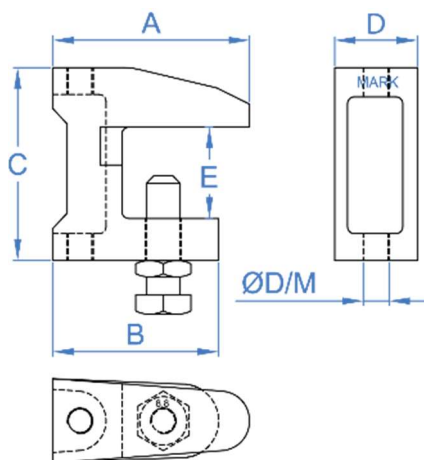

2.2 SU-CL

Clip suspension



Matériel



Acier

Revêtement



Phosphaté $\geq 5\mu\text{m}$

Données d'installation

Code	A	B	C	Ø PERÇAGE
	[mm]	[mm]	[mm]	[mm]
SUCL02	1,5 ÷ 4	28	14	6,3
SUCL04	4 ÷ 10	34	23	6,3
SUCL10	10 ÷ 15	40	23	6,3
SUCL15	15 ÷ 20	40	23	6,3

Plan

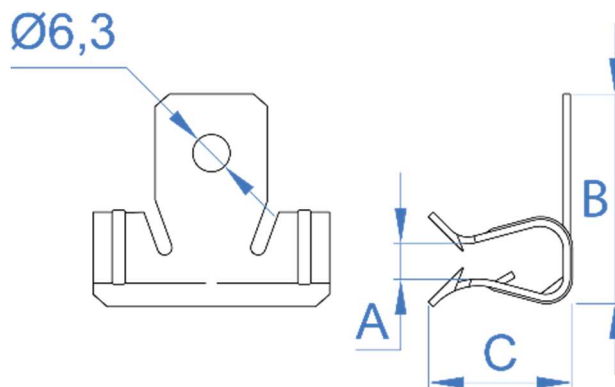

2.3 SU-VA

Clip angulaire pur tige filetée



Matériel



Acier

Revêtement



Phosphate $\geq 5\mu\text{m}$

Données d'installation

Code	A	B	C	W	Filetage (M)
	[mm]	[mm]	[mm]	[mm]	[mm]
SUVA0602	1,5 ÷ 4	50	14	28	M 6
SUVA0604	4 ÷ 10	54	23	40	M 6
SUVA0610	10 ÷ 15	60	23	40	M 6
SUVA0615	15 ÷ 20	60	23	40	M 6
SUVA0802	1,5 ÷ 4	50	14	28	M 8
SUVA0804	4 ÷ 10	54	23	40	M 8
SUVA0810	10 ÷ 15	60	23	40	M 8
SUVA0815	15 ÷ 20	60	23	40	M 8

Plan

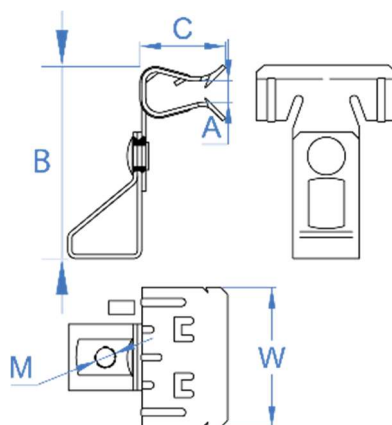

2.4 SU-CL

Clip droit pour éléments de suspension



Matériel	Revêtement
	
Acier	Phosphate $\geq 5\mu\text{m}$

Données d'installation

Code	A	B	C	Filetage (M)
	[mm]	[mm]	[mm]	[mm]
SUCU0602	1,5 ÷ 5	65	15	M 6
SUCU0605	5 ÷ 7	65	15	M 6
SUCU0606	3 ÷ 7	80	30	M 6
SUCU0607	7 ÷ 10	95	30	M 6

Plan

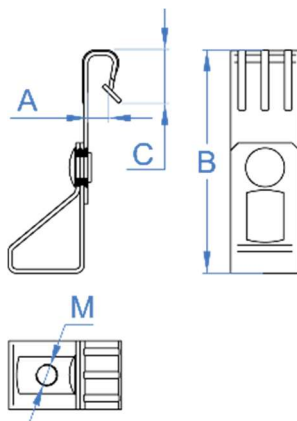

2.5 SU-AB

Clip de poutre pour pince



Matériel



Acier

Revêtement



Phosphate $\geq 5\mu\text{m}$

Données d'installation

Code	A	B	C	D	E	F	M1	M2	M3
	[mm]	[mm]	[mm]	[mm]	[mm]	[mm]	[mm]	[mm]	[mm]
SUAB0603	3 ÷ 7	30	36,5	33	45	15,4	M 6	M 6	M 6
SUAB0607	7 ÷ 13	36	36,5	33	45	15,4	M 6	M 6	M 6
SUAB0614	14 ÷ 20	43	36,5	33	45	15,4	M 6	M 6	M 6

Plan

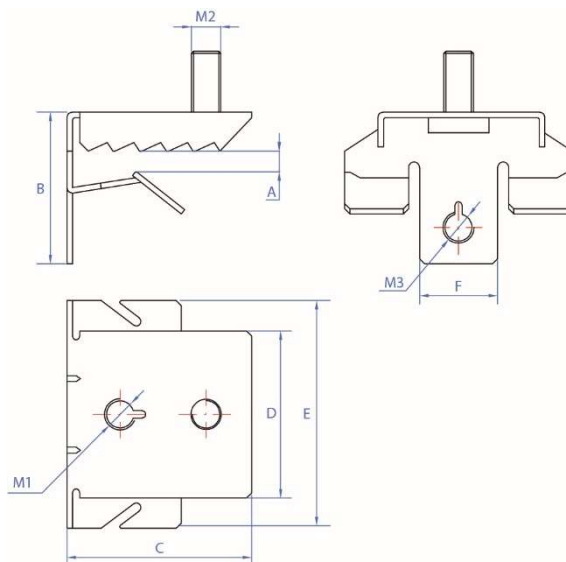

2.6 SU-CA

Clip de poutre pour câble



Acier

Revêtement



Phosphate $\geq 5\mu\text{m}$

Données d'installation

Code	A – Épaisseur	Diamètre du tube	B	C	D	E	F
	[mm]	[mm]					
SUCA0602	1 - 4	6 - 7	0,6	14,0	5,8	3,8	4,8
SUCA0604	4 - 7,5	6 - 7					8,0
SUCA0607	7,2 - 12	6 - 7					12,0
SUCA0802	1 - 4	8 - 9			8,0	5,8	4,8
SUCA0804	4 - 7,5	8 - 9					8,0
SUCA0807	7,2 - 12	8 - 9					12,0
SUCA1002	1 - 4	10 - 11			9,7	6,8	4,8
SUCA1004	4 - 7,5	10 - 11					8,0
SUCA1007	7,2 - 12	10 - 11					12,0
SUCA1202	1 - 4	12 - 14			11,0	7,5	4,8
SUCA1204	4 - 7,5	12 - 14					8,0
SUCA1207	7,2 - 12	12 - 14					12,0
SUCA1502	1 - 4	15 - 18			13,5	9,0	4,8
SUCA1504	4 - 7,5	15 - 18					8,0
SUCA1507	7,2 - 12	15 - 18					12,0
SUCA1902	1 - 4	19 - 24			18,5	11,5	4,8
SUCA1904	4 - 7,5	19 - 24					8,0
SUCA1907	7,2 - 12	19 - 24					12,0
SUCA2502	1 - 4	25 - 30			24,6	19,5	4,8
SUCA2504	4 - 7,5	25 - 30					8,0
SUCA2507	7,2 - 12	25 - 30	12,0				

Plan

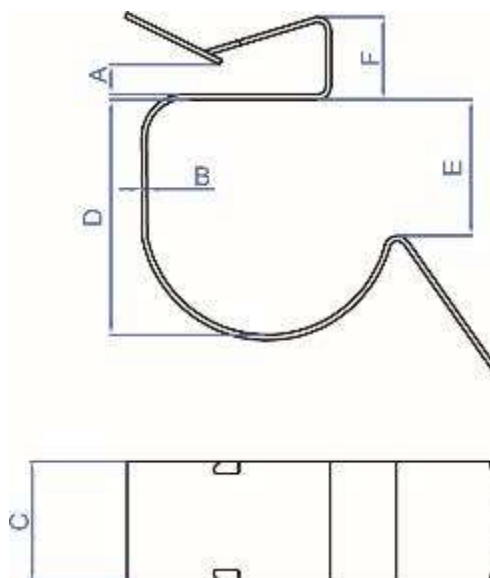

2.7 CO-AR

Crochet articulé



Matériel



Acier

Revêtement



Zinguée $\geq 5\mu\text{m}$

Données d'installation

CODE	$\varnothing M$ (mm)	$\varnothing M1$ (mm)	L1	Sw	Sw2
COAR08060	M8	M8	60	12,8 – 12,9	14,8 -14,9
COAR10060	M10	M10	61	16,8 – 16,9	16,8 – 16,9

Plan

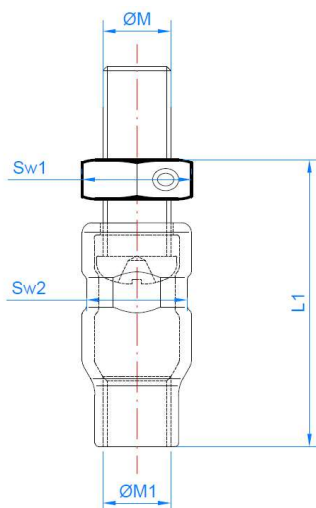

3. PROCEDURE D'INSTALLATION

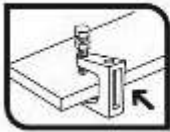
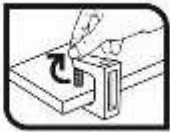
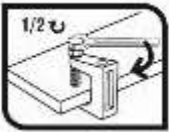
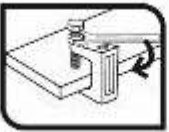
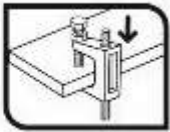
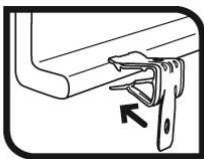
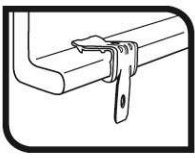
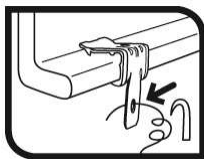
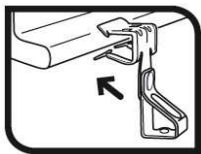
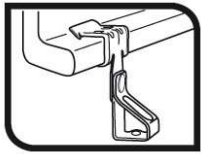
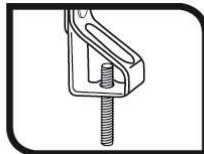
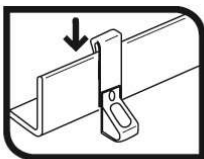
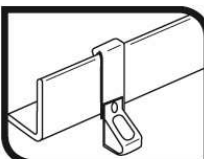
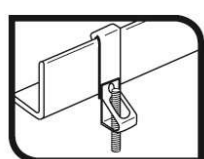
CODE	ÉTAPE 1	ÉTAPE 2	ÉTAPE 3	ÉTAPE 4	ÉTAPE 5
SU-MO					
	Étape 1: Placer le pince sur le profilé.				
	Step 2: Serrer la vis manuellement				
	Step 3: À l'aide d'une clé, serrez le boulon d'un demi-tour.				
	Step 4: Vissez le contre-écrou manuellement et serrez avec une clé 1/8 de tour.				
Step 5: Ajoutez l'élément à suspendre à la pince.					
CODE	ÉTAPE 1	ÉTAPE 2	ÉTAPE 3		
SU-CL					
	Étape 1: Placer le clip sur le profilé.				
	Étape 2: Frapper à coups de marteau sur le clip pour l'installer complètement.				
Étape 3: Placer l'élément de suspension souhaité.					
CODE	ÉTAPE 1	ÉTAPE 2	ÉTAPE 3		
SU-VA					
	Étape 1: Placer le clip sur le profilé.				
	Étape 2: Frapper à coups de marteau sur le clip pour l'installer complètement.				
Étape 3: Placer l'élément de suspension souhaité.					
CODE	ÉTAPE 1	ÉTAPE 2	ÉTAPE 3		
SU-CU					
	Étape 1: Placer le clip sur le profilé.				
	Étape 2: Frapper à coups de marteau sur le clip pour l'installer complètement.				
Étape 3: Placer l'élément de suspension souhaité.					

CODE	ÉTAPE 1	ÉTAPE 2	ÉTAPE 3	
SU-AB				
	Étape 1: Placer le clip sur le profilé.			
	Étape 2: Frapper à coups de marteau sur le clip pour l'installer complètement.			
	Étape 3: Placer l'élément de suspension souhaité.			
CODE	ÉTAPE 1	ÉTAPE 2	ÉTAPE 3	ÉTAPE 4
SU-CA				
	Étape 1: Placer le clip sur le profilé.			
	Étape 2: Frapper à coups de marteau sur le clip pour l'installer complètement.			
	Étape 3: Faire pression sur le clip jusqu'à ce que le tube est fixé			
Étape 4: Placer l'élément de suspension souhaité.				

4. RESISTANCES

PHOTO	CODE	CHARGES MAXIMALES RECOMMANDÉES [kg]
	SUMOP09	120
	SUMOP11	250
	SUMOP13	350
	SUMOM06	120
	SUMOM08	120
	SUMOM10	250
	SUMOM12	350
	SUCL02	70
	SUCL04	
	SUCL10	
	SUCL15	
	SUVA0602	70
	SUVA0604	
	SUVA0610	
	SUVA0615	
	SUVA0802	
	SUVA0804	
	SUVA0810	
	SUVA0815	
	SUCU0602	70
	SUCU0605	
	SUCU0606	
	SUCU0607	
	SUAB0603	40
	SUAB0607	
	SUAB0614	
	COAR08060	120
	COAR10060	150